



**OUTDOOR-RATED ENCLOSED  
VARIABLE FREQUENCY DRIVE  
200V – 230V – 460V – 575V**



**Carry Pumps, Inc. • 1360 Prospect Ave. • Caro, MI 48723  
www.carrypumps.com • (800) 492-2779 • sales@carrypumps.com**



# VARIABLE FREQUENCY DRIVE INSTALLATION WIRING

## 200V and 230V

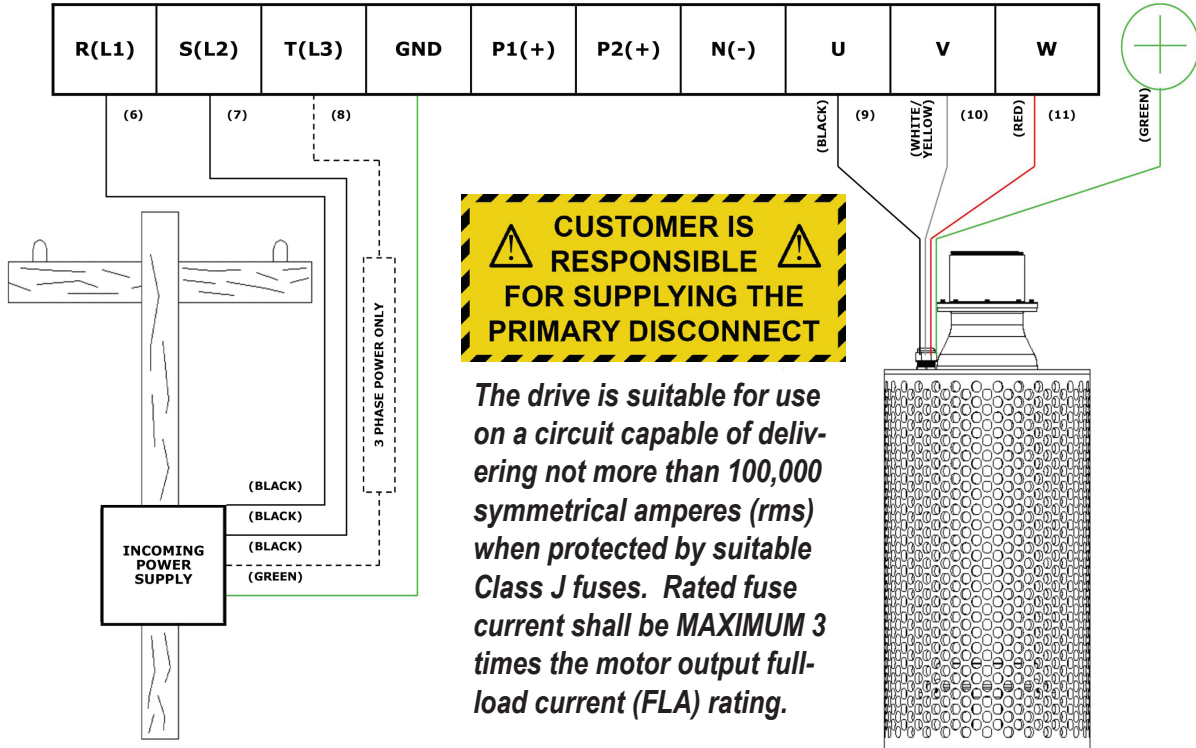

## 460V and 575V

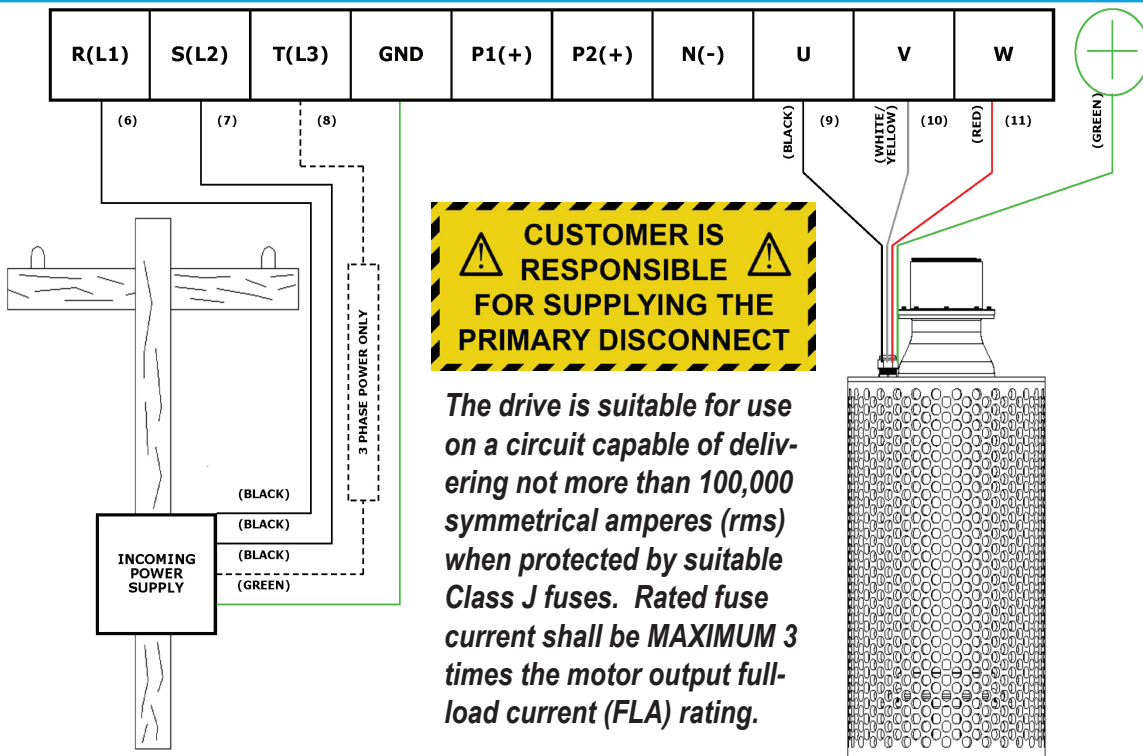



# VARIABLE FREQUENCY DRIVE ENCLOSURE WIRING

200V and 230V

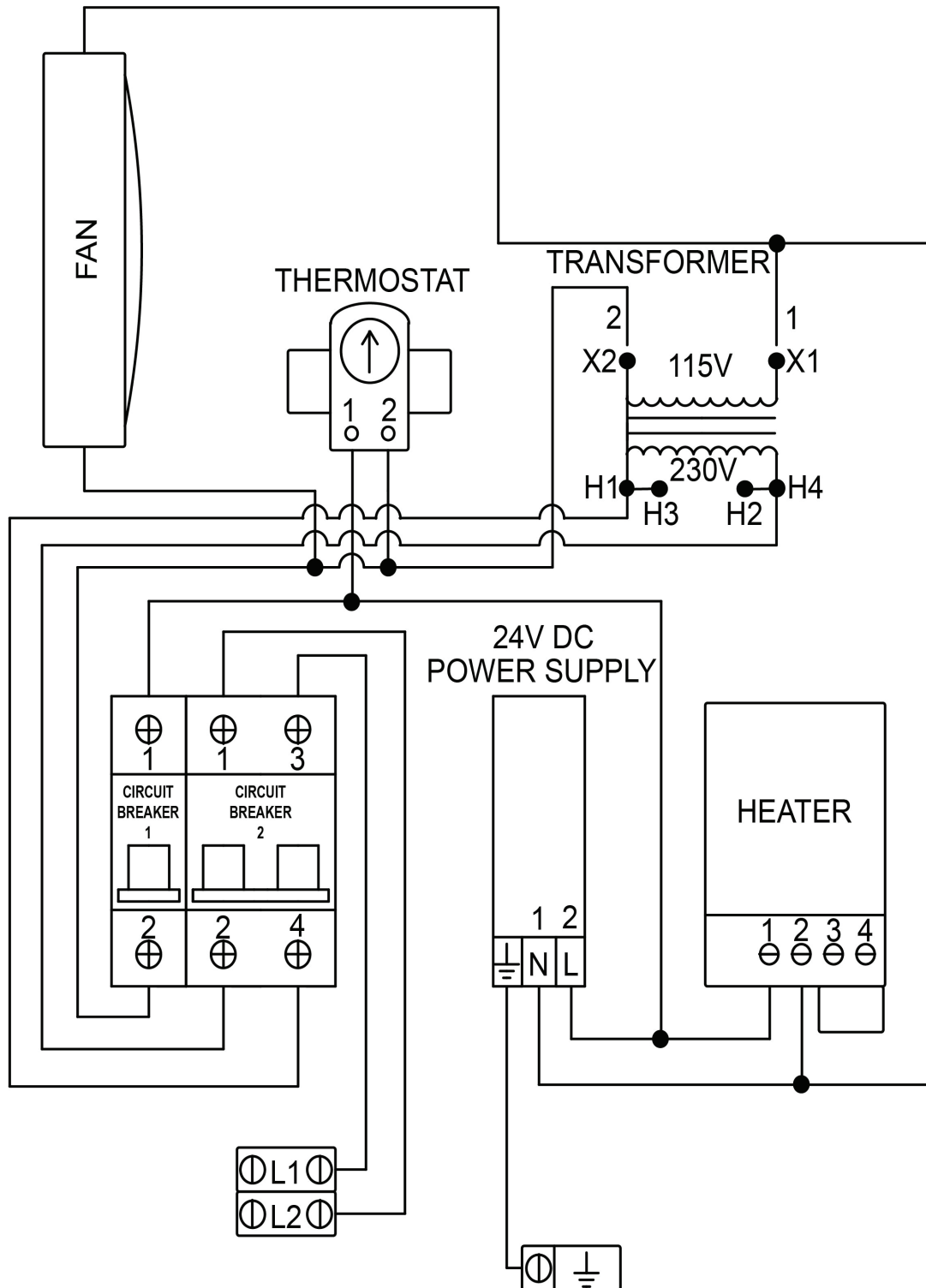



# VARIABLE FREQUENCY DRIVE ENCLOSURE WIRING

460V

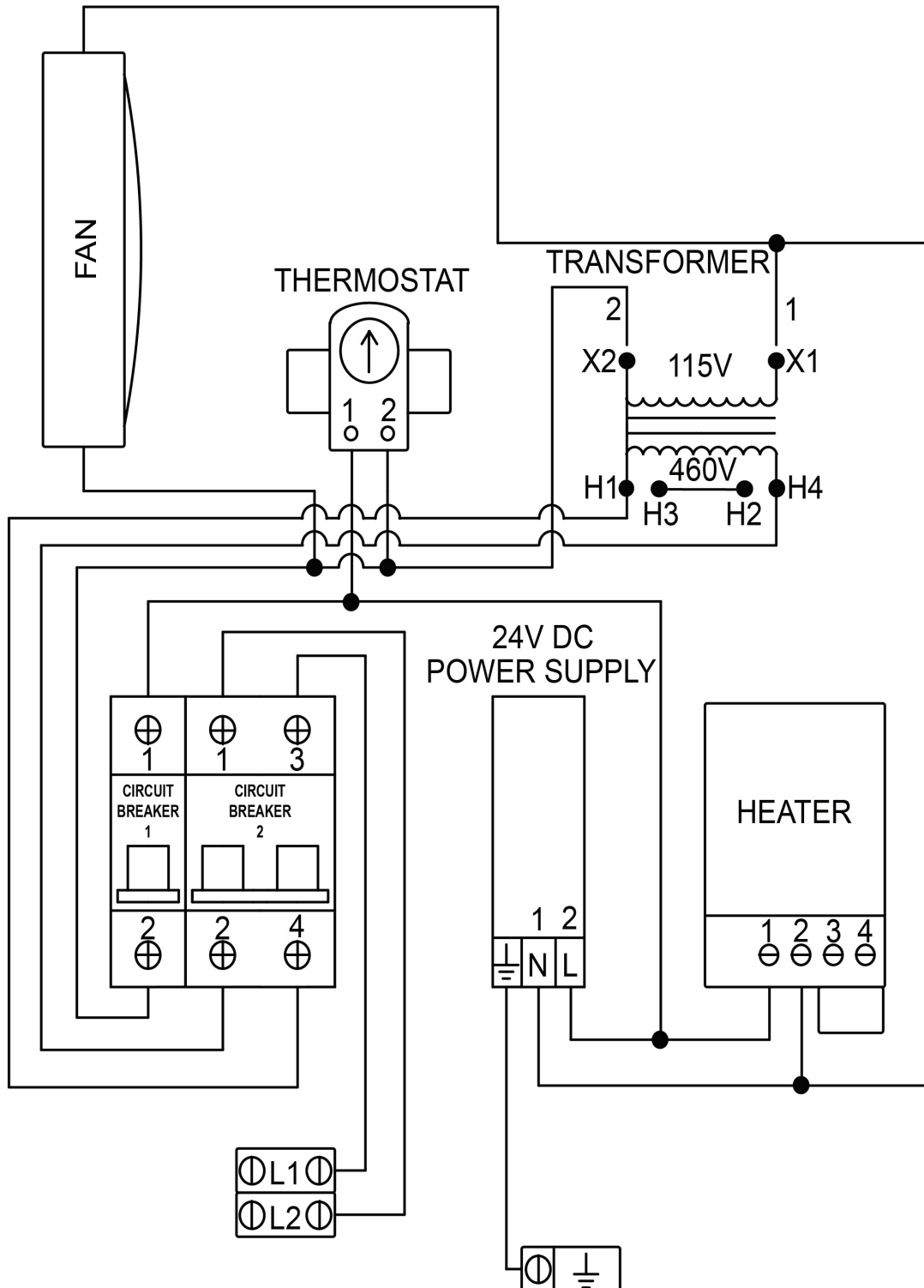





# ENCLOSED VFD LEVEL TRANSDUCER & REMOTE MONITORING

## TRANSDUCER KIT with HOUSING & 32 Ft. CABLE

The transducer senses the water level in the sump to turn the VFD Drive on and off. The transducer also increases and decreases the speed of the pump as the water level in the sump rises and falls.

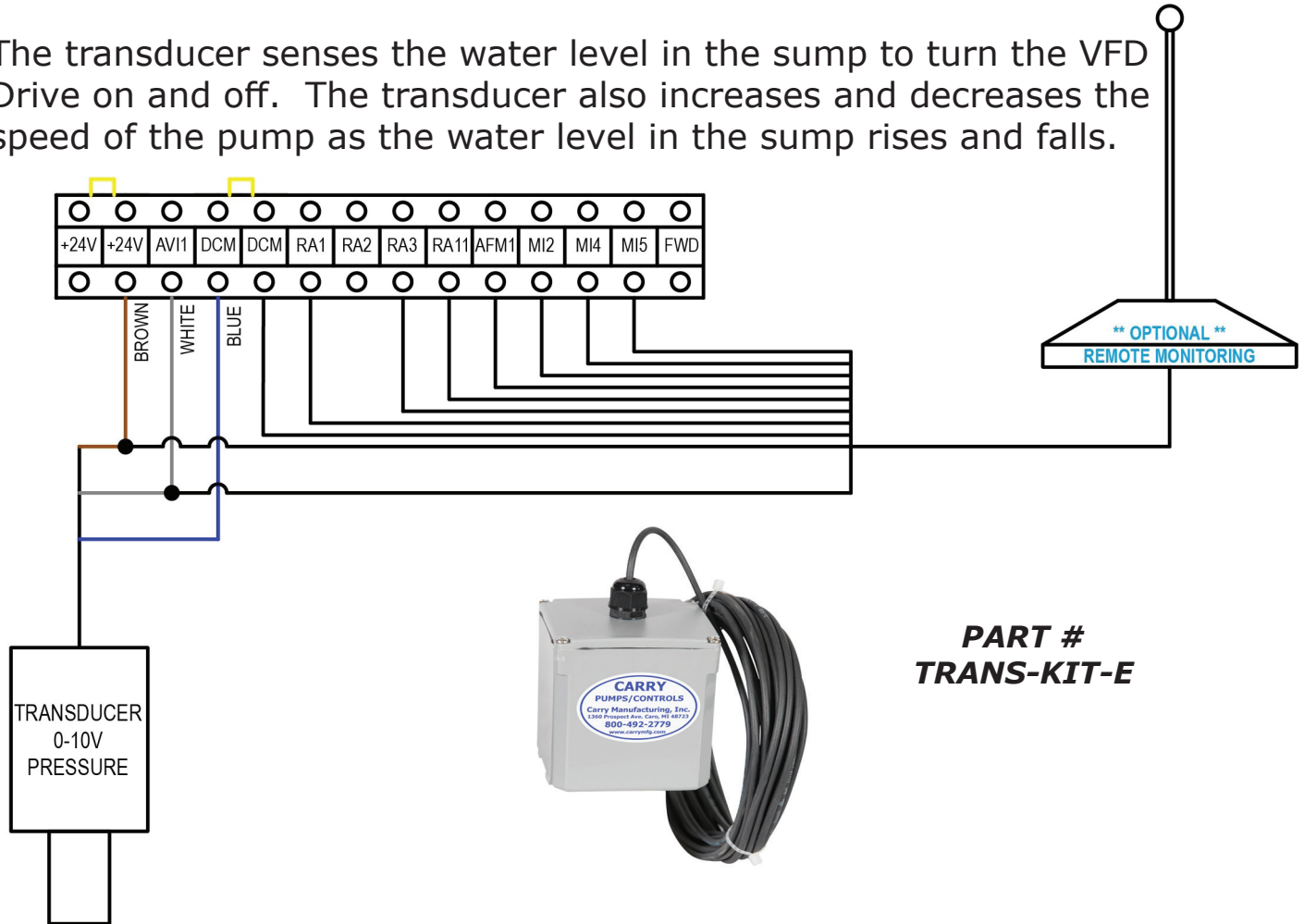

**PART #  
TRANS-KIT-E**

## Eagle I REMOTE MONITORING SYSTEMS

The Eagle I Remote Monitoring System keeps you informed by sending you a text message when certain preprogrammed conditions exist with your pumping system, such as, if there is a power failure, or if there is a low/high water situation in your sump.



**Requires Annual Service: Part #RMS-SERVICE**

**230V: PART #RMS-VFD-23E  
460V: PART #RMS-VFD-46E**

**Carry Pumps, Inc. • 1360 Prospect Ave. • Caro, MI 48723  
www.carrypumps.com • (800) 492-2779 • sales@carrypumps.com**



# VARIABLE FREQUENCY DRIVE TRANSDUCER SWITCH WIRING

*shown with optional  
REMOTE MONITORING*

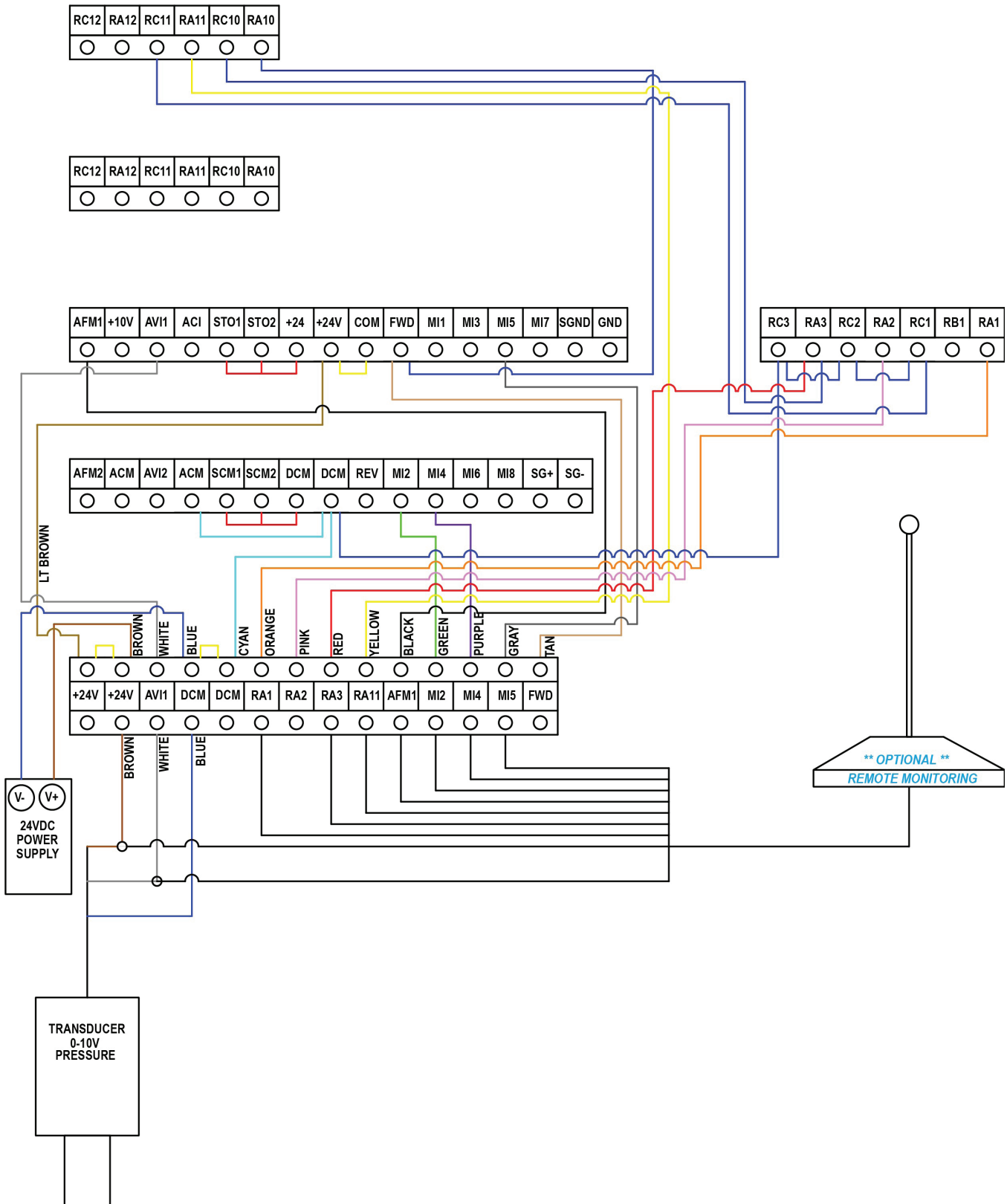



# ENCLOSED VFD ACCESSORIES

## EXTERIOR 5-COLOR LED SIGNAL LIGHT

*\* OPTIONAL \*  
LED LIGHT*



**FAULT**



**DISABLED**



**RUNNING**



**AUTO  
MODE**



**MANUAL  
MODE**

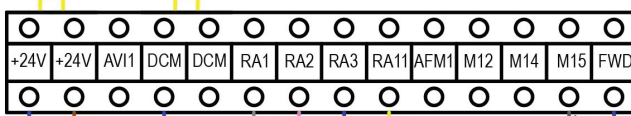

*PART #  
LED-LIGHT-KIT-E*

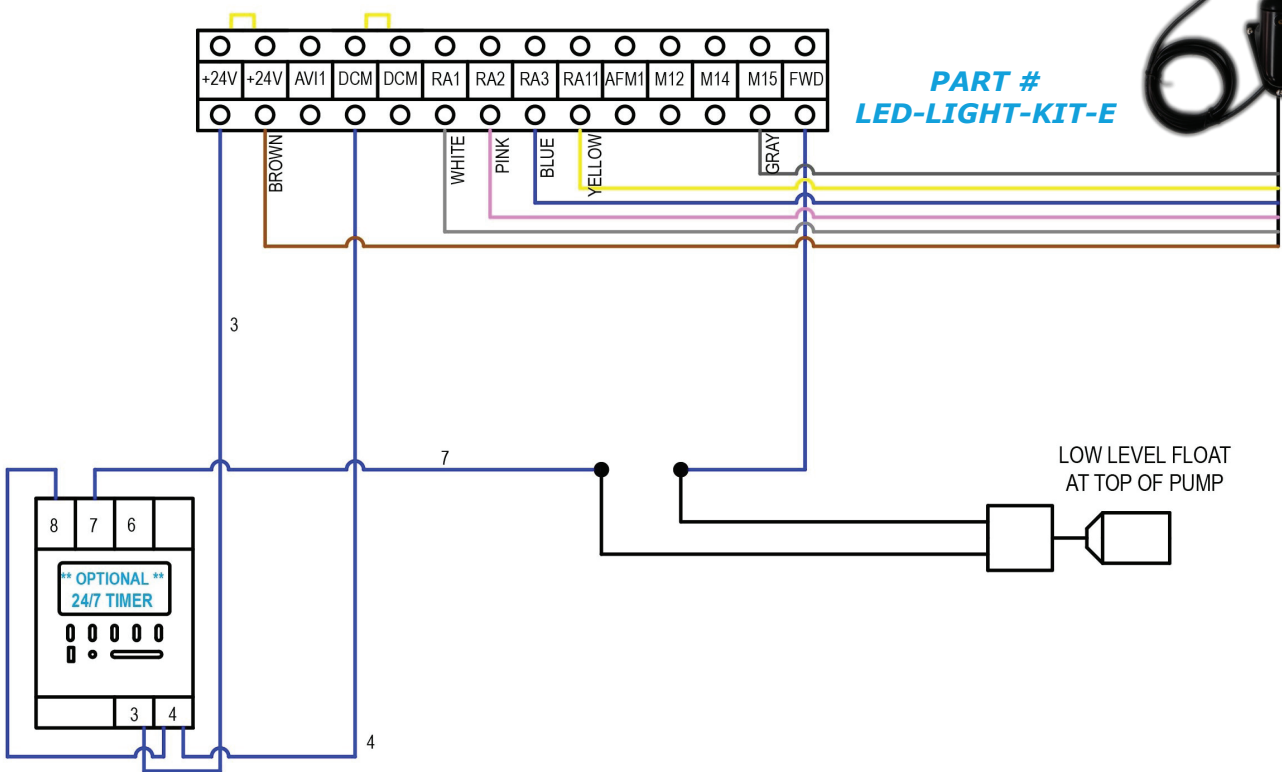

## 24/7 TIMER

## LOW-LEVEL "OFF" FLOAT



**PART #TIMER-24/7-24V-DR**



**PART #100-21-35**

**Carry Pumps, Inc. • 1360 Prospect Ave. • Caro, MI 48723**  
**www.carrypumps.com • (800) 492-2779 • sales@carrypumps.com**



# VARIABLE FREQUENCY DRIVE LOW-LEVEL FLOAT WIRING

*shown with optional  
24/7 TIMER and LED LIGHT*

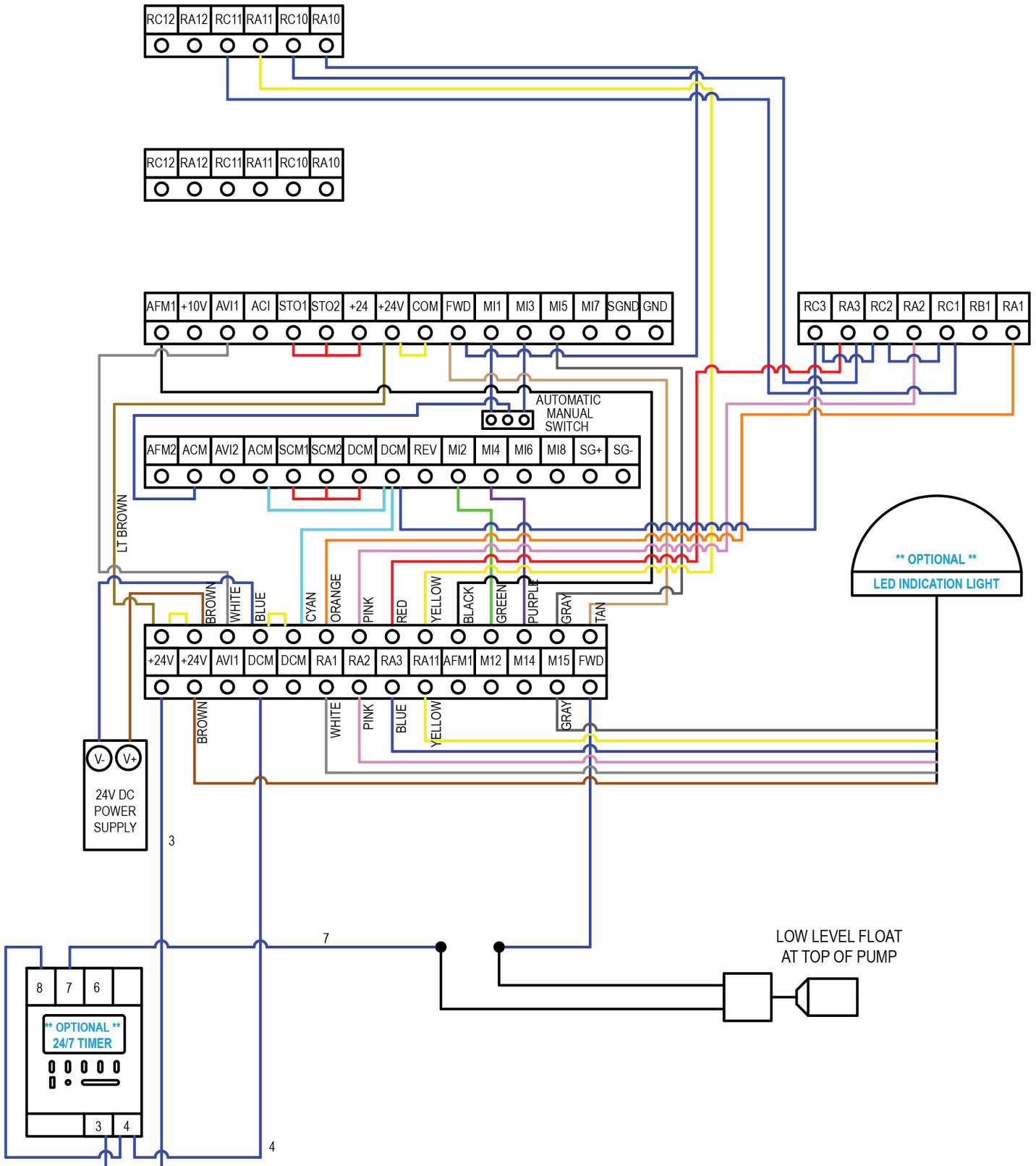



# USING THE KEYPAD

**1** Move the Automatic/Manual switch located to the right of the VFD from "AUTOMATIC" to "MANUAL".



**2** From the Home Screen, press the [MENU] key to open the Parameter Groups listing. The [ENTER] key is also used to advance to the next screen and to save changes made to parameter settings



**3** Press the UP [▲] or DOWN [▼] key to scroll to the Param Group containing the parameter you need to change (Example: 08:Advance 2). Then press [ENTER] to advance to the next screen.



**4** Press the UP [▲] or DOWN [▼] arrow keys to scroll to the specific Parameter you need to change. (Example: [ADVANCE 2 08-09] AVI1 Low Value. Then press [ENTER] to advance to the next screen.



**5** To make changes, press the RIGHT [▶] and/or LEFT [◀] arrow keys to move to the specific digit(s) you need to change, and then use the UP [▲] and DOWN [▼] arrow keys to adjust the selected digit(s). (Example: 2.00)

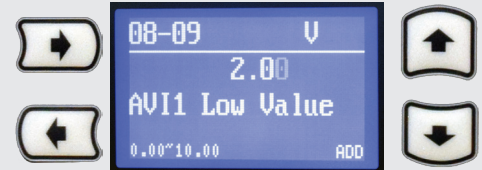

**6** Press the [Enter] key to accept the change. "END" will flash momentarily. Then the digits will return to flashing.



**7** Press the [Back] key to return to the previous screen or Press [ESC] to return to the Home screen if you are finished making changes.



**8** Repeat Steps 3 through 7 to change other parameter(s) as needed.

**9** When you are done making changes, be sure to switch the Automatic/Manual switch on the front of the VFD from "MANUAL" back to "AUTOMATIC".

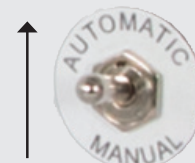



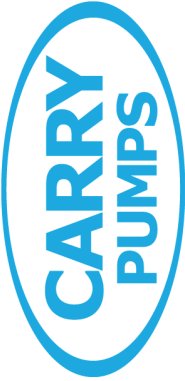

# PUMP STATION EXAMPLE with VARIABLE SPEED DRIVE (VFD)

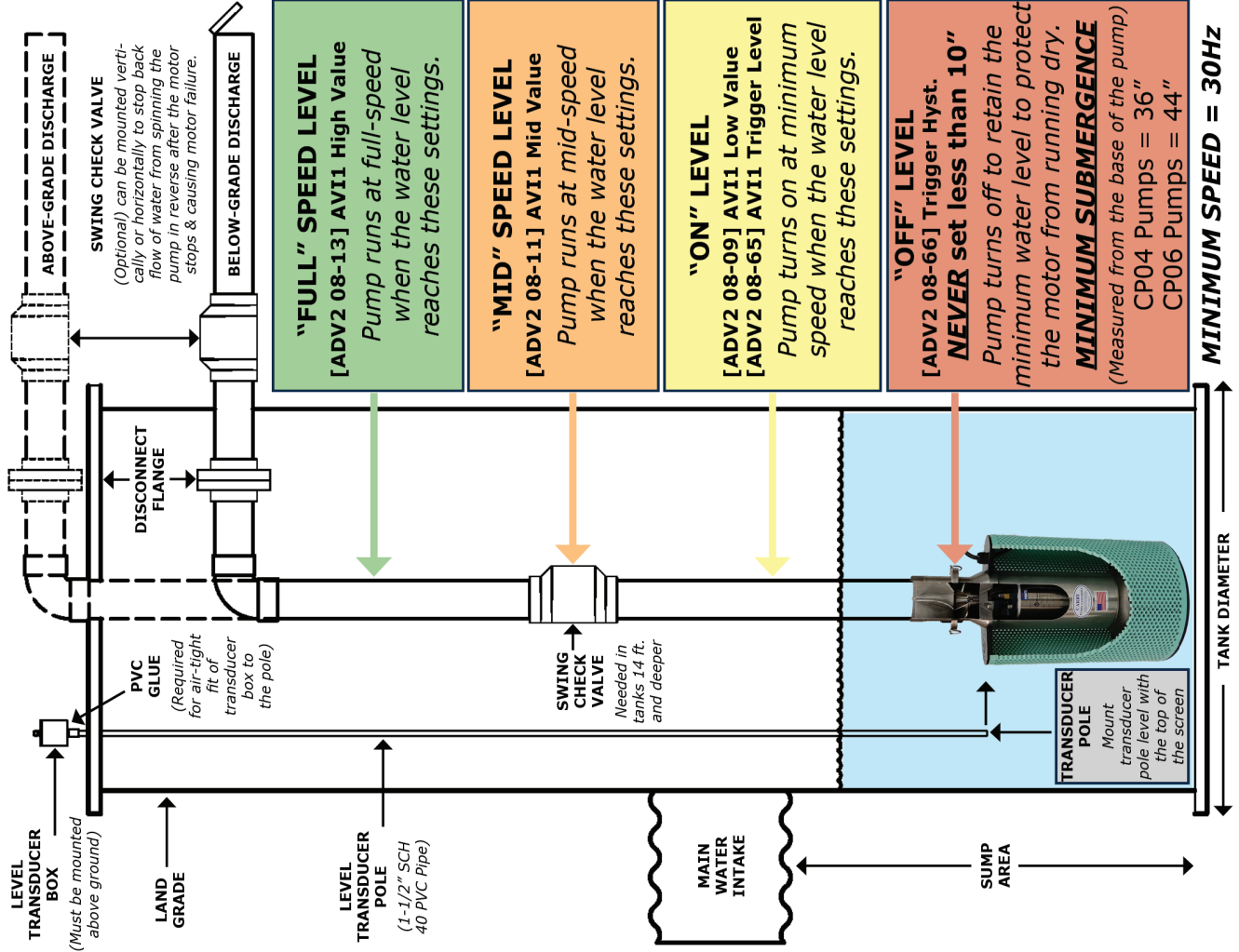

# ADJUSTING WATER LEVEL SETTINGS

Water Level Above Pump	Set	Parameter Group Screen	Parameter List Screen	Parameter Set Screen
<b>Factory Setting</b>				
30" "FULL" SPEED	3.00	Param Groups 08: ADVANCE 2 09: MOTOR 10: CHANGED PAR	ADVANCE 2 08-13 AV11 Hi Value AV11 High % ACI Low Value	08-13 V 3.00 AV11 Hi Value 0.00*10.00
25" "MID" SPEED	2.50	Param Groups 08: ADVANCE 2 09: MOTOR 10: CHANGED PAR	ADVANCE 2 08-11 AV11 Mid Value AV11 Mid % AV11 Hi Value	08-11 V 2.50 AV11 Mid Value 0.00*10.00
20" "ON" LEVEL	2.00	Param Groups 08: ADVANCE 2 09: MOTOR 10: CHANGED PAR	ADVANCE 2 08-09 AV11 Low Value AV11 Low % AV11 Mid Value	08-09 V 2.00 AV11 Low Value 0.00*10.00
10" "OFF" LEVEL	10	Param Groups 08: ADVANCE 2 09: MOTOR 10: CHANGED PAR	ADVANCE 2 08-65 Trigger Level Trigger Hyster	08-65 inWC 20.0 Trigger Level 0.00*10.00
10" "OFF" LEVEL	10	Param Groups 08: ADVANCE 2 09: MOTOR 10: CHANGED PAR	ADVANCE 2 08-66 Trigger Hyster P-Fill Low Freq	08-66 inWC 10.0 Trigger Hyster 0.00*100.00
<b>Level Option 1</b>				
Water Level Above Pump	Set	Parameter Group Screen	Parameter List Screen	Parameter Set Screen
35" "FULL" SPEED	3.50	08: ADVANCE 2	AV11 Hi Value	08-13
30" "MID" SPEED	3.00	08: ADVANCE 2	AV11 Mid Value	08-11
25" "ON" LEVEL	2.50	08: ADVANCE 2	AV11 Low Value	08-09
10" "OFF" LEVEL	25	08: ADVANCE 2	Trigger Level	08-65
10" "OFF" LEVEL	10	08: ADVANCE 2	Trigger Hyster	08-66
<b>Level Option 2</b>				
Water Level Above Pump	Set	Parameter Group Screen	Parameter List Screen	Parameter Set Screen
45" "FULL" SPEED	4.50	08: ADVANCE 2	AV11 Hi Value	08-13
35" "MID" SPEED	3.50	08: ADVANCE 2	AV11 Mid Value	08-11
25" "ON" LEVEL	2.50	08: ADVANCE 2	AV11 Low Value	08-09
10" "OFF" LEVEL	25	08: ADVANCE 2	Trigger Level	08-65
10" "OFF" LEVEL	10	08: ADVANCE 2	Trigger Hyster	08-66

**"OFF" LEVEL**  
[ADV2 08-66] Trigger Hyst.  
**NEVER set less than 10"**  
Pump turns off to retain the minimum water level to protect the motor from running dry.  
**MINIMUM SUBMERGENCE**  
(Measured from the base of the pump)  
CP04 Pumps = 36"  
CP06 Pumps = 44"

**MINIMUM SPEED = 30HZ**

PARAMETER	NAME	SETTING	DESCRIPTION
SET 00-00	Application Set	(0) Basic	General VFD Factory Setting
SET 00-01	Input Phase	(1) 1 Phase (0) 3 Phase	Incoming Power Phase
SET 00-02	Motor HP	XX.X HP	Motor Horsepower
SET 00-03	Motor FLA/SFA	XX.X A	Service Factor Amps
SET 00-04	Motor RPM	3450	Franklin Submersible Motor RPM
SET 00-05	Motor Voltage	0 to XXX V	200V/230V = 255V, 460V = 510V, 575V = 637V
SET 00-06	Motor Freq Sel	(1) 60.00 Hz	Motor Frequency
SET 00-07	Auto Speed Ref	(2) AV11 Analog Input	Uses [IO 02-21], [IO 02-23] & [IO 02-25]
SET 00-08	Auto Run Cmd	(1) Digital Input	Source of Run Command in "Auto" Mode
SET 00-09	Hand Speed Ref	(0) Keypad	Source of Speed Reference when in "Hand" (manual) Mode
SET 00-10	Hand Run Cmd	(0) Keypad	Source of Run Command in "Hand" (manual) Mode
SET 00-11	Accel Time	1 Sec	Accelerate from 0 to Max Freq
SET 00-12	Decel Time	1 Sec	Decelerate from Max Freq to 0
SET 00-13	Low Freq Limit	30 Hz	Lowest frequency (speed)
SET 00-14	High Freq Limit	60 Hz	Highest frequency (speed) <b>Set [VFD 01-00] to 60 Hz First</b>
SET 00-41	ULD Select	(1) By Current	Underload Detection protects against dry running.
SET 00-42	ULD Level	40%	% of SFA [SET 00-03]
SET 00-43	ULD Frequency	30 Hz	30 Hz Frequency
SET 00-44	ULD Delay	10 Sec	Underload Delay timer
SET 00-45	ULD Recovery T	1 Min	Underload Time restarts VFD
SET 00-47	HLD Select	(1) By Current	High Load Detection protects against over-current damage.
SET 00-48	HLD Level	110%	High Load Detection Level = 110% of SFA [SET 00-03]
SET 00-49	HLD Frequency	30 Hz	High Load Detection frequency
SET 00-50	HLD Delay	2 Sec	High Load Delay timer
SET 00-57	Display Line 1	(1) Output Freq	Factory Setting
SET 00-58	Display Line 3	(22) Aux Analog Input	Factory Setting
SET 00-60	HOA Mode Source	(1) Keypad	Sets the input that selects between Hand-Off-Auto

PARAMETER	NAME	SETTING	DESCRIPTION
VFD 01-00	VFD Max Freq	60 Hz	"Max" frequency (speed)
VFD 01-05	Step Freq-2	30 Hz	"On" frequency (speed)
OPT 07-06	Relay Exp. RA10	(17) Analog Triggering	Factory Setting
OPT 07-07	Relay Exp. RA11	(8) Fault	Factory Setting
ADV2 08-09	AV11 Low Value	2.0 V	"On Level" at 20" of water
ADV2 08-10	AV11 Low %	50%	% of Max Speed = 50%
ADV2 08-11	AV11 Mid Value	2.5 V	"Half Speed Level" at 25" of water
ADV2 08-12	AV11 Mid %	73%	% of Max Speed = 73%
ADV2 08-13	AV11 High Value	3.0 V	"Full Speed Level" at 30" of water
ADV2 08-14	AV11 High %	100%	% of Max Speed = 100%
ADV2 08-58	Aux AI Select	(0) AV11	Factory Setting
ADV2 08-59	Aux AI Unit	(1) in WC	Factory Setting
ADV2 08-61	Aux Max Value	100 in	Factory Setting
ADV2 08-62	Analog Trigger	(1) Relay	Factory Setting
ADV2 08-63	Trigger Source	(1) Aux A1	Factory Setting
ADV2 08-64	Trigger Type	(1) Higher	Factory Setting
ADV2 08-65	Trigger Level	(20.0) Trigger Level	"On Level" at 20" of water
ADV2 08-66	Trigger Hyst.	(10.0) Trigger Hyst.	"Off Level" must always be 10.0 for 1.0" of water <b>MINIMUM</b>
I/O 02-21	MI1 Define	(27) HOA-Auto	Auto = "Automatic" Mode
I/O 02-23	MI3 Define	(26) HOA-Hand	Hand = "Manual" Mode
I/O 02-25	MI5 Select	(35) Shutdown N-Latch	"Off"
I/O 02-47	Relay RA1	(1) Run	"Run" Mode
I/O 02-48	Relay RA2	(44) Hand Mode	"Hand" (manual) Mode
I/O 02-49	Relay RA3	(45) Auto Mode	"Automatic" Mode
PROT 04-07	OCA Level	98%	Set Over-Current for Acceleration level on rated current & selected duty level [VFD 35]
PROT 04-08	OCN Level	98%	Set Over-Current for Operation level on rated current and selected duty level [VFD 35]
PROT 04-10	Auto Restarts	(3) Auto Restarts	Drive will automatically attempt to restart 3 times
PROT 04-11	Auto Retry Delay	30 Sec	Drive will wait 30 seconds before attempting to restart
PROT 04-45	Fan Control	(3) By Temp.	Turns fan on/off based on temperature in the enclosure

## TERMS, PAYMENT & INVOICING

Standard payment terms are NET 30 days from the date of invoice for approved accounts. Customers who do not have an approved account must prepay prior to order being shipped. Retaining a percentage of the contract sale amount is prohibited without prior, written agreement. Payment must be made in U.S. Funds. An invoice will be rendered as of the date product is ready for shipment. A service fee of 1-1/2% per month on all invoices over 30 days past due will be imposed. In the event of any default by the Purchaser, Carry Pumps, Inc. shall have the right to repossess the product as well as all other rights afforded to a conditional seller under the provisions of the Uniform Conditional Sales Act and any other applicable laws.

### STANDARD WARRANTY AND CONDITIONS OF SALE

LIMITED WARRANTY: CARRY PUMPS, INC. warrants the pump system products sold by it to be free from defects in materials and workmanship for a period of one (1) year from the date of purchase.

WARRANTY DISCLAIMER: *This warranty does not apply to pumps sold without compatible Carry electrical controls, horizontal pumps, and/or if the product is used in saltwater, aquaculture (fish farming), water feature applications, continuous-duty use (24/7 operation), or to pumps that have been subject to misuse (including use in a manner inconsistent with the design of the pump), abuse, neglect, accident or improper installation or maintenance, or to pumps that have been altered or repaired by anyone other than CARRY PUMPS, INC.* The warranties in this agreement are in lieu of all other warranties, express or implied, including without limitation, any warranties of merchantability or fitness for a particular purpose, said warranties being expressly disclaimed.

WARRANTY AMENDMENTS: Prior or subsequent courses of dealing, trade usage and verbal agreements not reduced to a writing signed by CARRY PUMPS, INC., to the extent they differ from, modify, add to or detract from this warranty shall not be binding upon CARRY PUMPS, INC.. There are no agreements, promises or understandings, either verbal or written, that are not fully expressed in this warranty. No statements, recommendations or assistance by either party have been relied upon by either party nor shall they be relied upon and shall not constitute a waiver by either party of any of the provisions hereof. This warranty may be amended or altered only if agreed to in writing signed by CARRY PUMPS, INC.

LIMITED REMEDY: CARRY PUMPS, INC. and Purchaser agree the repair or replacement of the pump system product at issue is a commercially reasonable allocation of risk and, therefore, Purchaser agrees that its sole and exclusive remedy against CARRY PUMPS, INC. shall be limited to the repair or replacement of the pump system product at issue. This exclusive remedy shall not be deemed to have failed of its essential purpose so long as CARRY PUMPS, INC. is willing and able to repair or replace the pump system product at issue. In the event CARRY PUMPS, INC. is unable to repair or replace the pump system product at issue in a manner acceptable to purchaser, or in the event it shall be determined by a court having jurisdiction thereof that any provisions of this warranty are unconscionable or fail in its essential purpose, then the maximum liability of CARRY PUMPS, INC. shall be that as set forth in the paragraph next following entitled "Limitation on Liability".



## STANDARD WARRANTY AND CONDITIONS OF SALE

**LIMITATION ON LIABILITY:** CARRY PUMPS, INC. shall not be liable for any loss, damage or injury resulting from delay in delivery or installation of the pump system product or for any failure to perform which is due to circumstances beyond its control. CARRY PUMPS, INC. and Purchaser agree it is a commercially reasonable allocation of risk that the maximum liability, if any, of CARRY PUMPS, INC. for all damages, including without limitation contract damages and damages for injuries to persons or property, whether arising from CARRY PUMPS, INC.' breach of this agreement, breach of warranty, negligence, strict liability or other tort, is limited to an amount not to exceed the purchase price of the pump system product at issue in the dispute and said liability is so limited. In no event shall CARRY PUMPS, INC. be liable to Purchaser for any incidental, consequential or special damages, including without limitation, lost revenues and profits, even if it has been advised of the possibility of such damages.

**WARRANTY CLAIM PROCEDURE:** This warranty is valid only if the following conditions are complied with by the Purchaser: Purchaser shall notify CARRY PUMPS, INC. in writing of the defect in the pump system product at issue within 30 days of discovery of the defect. The notice shall include with it copies of the proof of purchase and the return receipt signed by a representative of CARRY PUMPS, INC. as provided above. In the event repair or replacement of the pump system product at issue is approved by CARRY PUMPS, INC., Purchaser shall, upon written notice by CARRY PUMPS, INC. of the approval, return the pump system product to CARRY PUMPS, INC., freight pre-paid. CARRY PUMPS, INC. will return the repaired or replaced pump system product to Purchaser, freight prepaid. The repair or replacement of the pump system product shall not extend the duration of the one-year warranty term.

**GOVERNING LAW:** This warranty shall be governed and controlled by and enforced in accordance with the laws of the State of Michigan, U.S.A., in all respects.

**FORUM:** The parties agree they are of equal bargaining power and irrevocably submit to the jurisdiction and venue of the Circuit Court for the County of Tuscola, State of Michigan, or if original jurisdiction can be established, the United States District Court for the Eastern District of Michigan, Northern Division, with respect to any performance or breach of this agreement. The parties hereby stipulate that the venues referenced in this agreement are convenient to each of them.

**RETURNS:** Authorization and shipping instructions for the return of any product must first be obtained by the Purchaser from CARRY PUMPS, INC. or the shipment will be refused. Only unused, standard product or materials of current design by CARRY PUMPS, INC. will be considered for return. Products are not eligible for return more than 6 months after the initial ship date of the product. Custom products cannot be returned for credit. If the returned product is in sellable condition, a credit memorandum will be issued for the original purchase price, less a minimum restocking charge of 20%. If there are any shipping charges that were paid by Carry Pumps, Inc., the amount of those shipping charges will also be deducted from the credit amount.

**GENERAL:** These terms and conditions shall constitute a part of any contract which may be entered into and shall not be altered, modified, or added to unless specifically and expressly agreed to in writing by CARRY PUMPS, INC. All oral agreements and representations of CARRY PUMPS, INC. or its representative to the Purchaser shall be embodied in any written contract of which CARRY PUMPS, INC. is a part.