

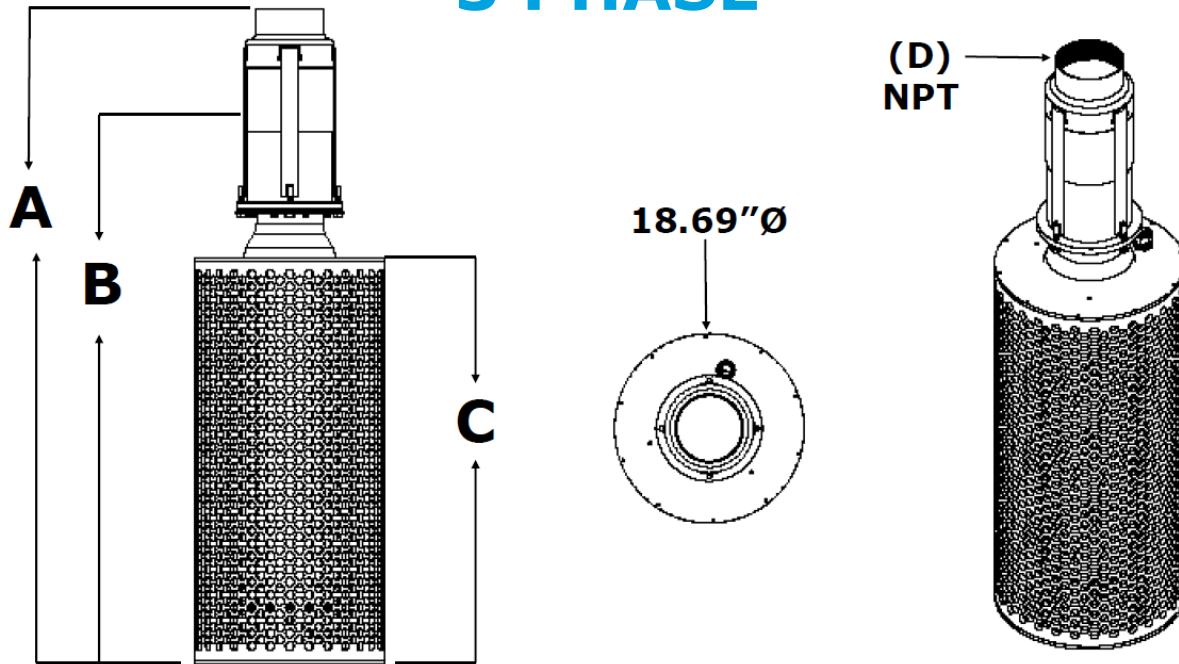

CP06 SERIES HIGH-PRESSURE TURBINE PUMP DIMENSIONS 3 PHASE



3 PHASE

HORSEPOWER	PHASE	WEIGHT	(A) PUMP HEIGHT	(B) MINIMUM SUBMERGENCE	(C) SCREEN HEIGHT	(D) NPT
5 HP	3 Phase	190	39.00"	35.00"	24.50"	4"
7.5 HP	3 Phase	225	47.50"	37.50"	26.50"	5"
10 HP	3 Phase	245	49.00"	39.00"	27.50"	5"
15 HP	3 Phase	270	52.00"	42.00"	30.00"	6"
20 HP	3 Phase	300	55.00"	45.00"	33.00"	6"
25 HP	3 Phase	320	58.00"	48.00"	37.00"	6"
30 HP	3 Phase	350	62.00"	50.00"	39.50"	6"
40 HP	3 Phase	390	63.00"	56.00"	42.00"	6"



CP06 SERIES HIGH-PRESSURE TURBINE PUMP

