

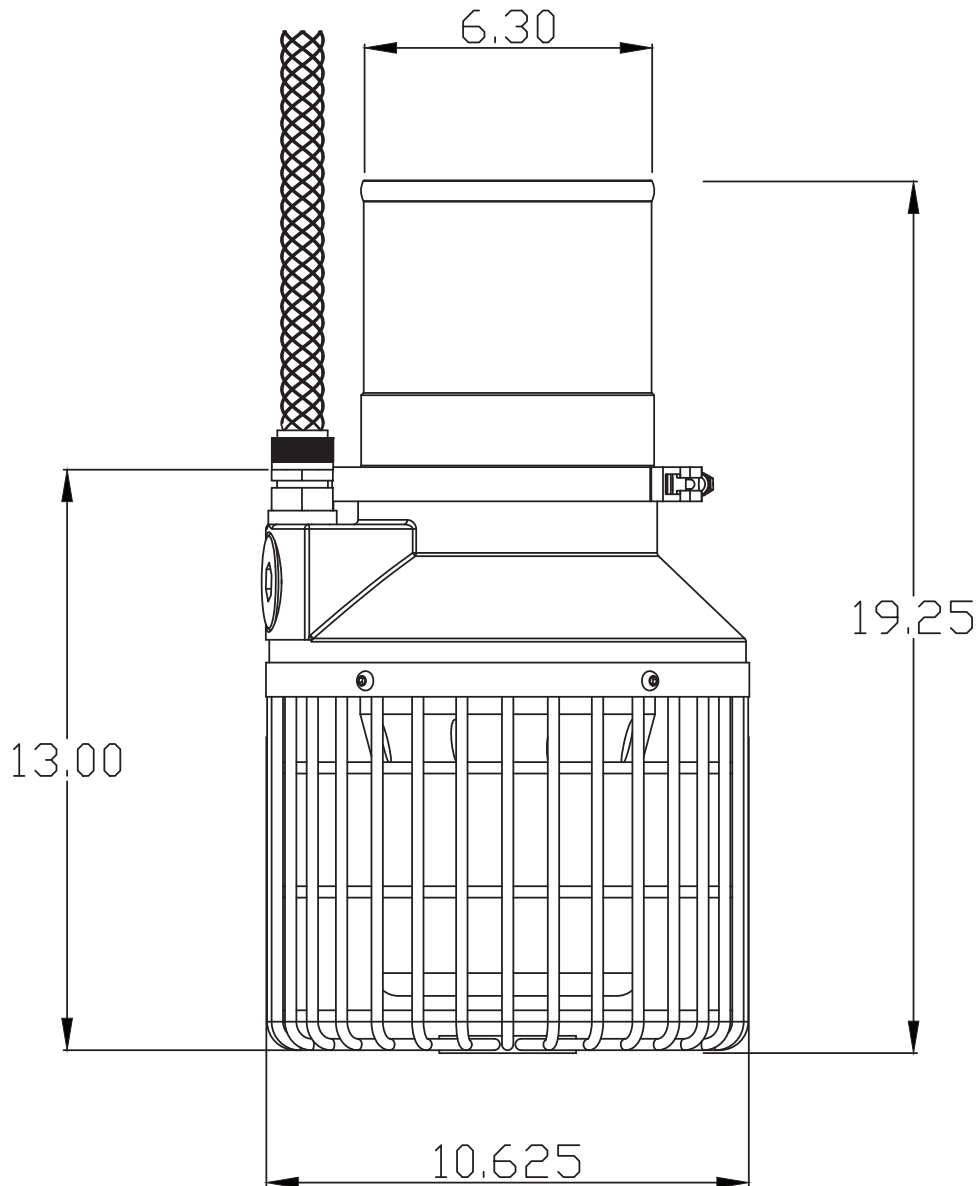

SNORKEL S1 PUMP DIMENSIONS



PUMP WEIGHT WITH 30 FOOT LEAD = 60 LBS

Carry Pumps, Inc. | 1360 Prospect Ave | Caro, MI 48723
(800) 492-2779 | www.carrypumps.com | sales@carrypumps.com



SNORKEL S1 PUMP SPECIFICATIONS

MOTOR	7.5 Horsepower 3 Phase 400 Hz 3800 RPM
PUMP SHELL	Aluminum Investment Casting CNC Precision Machined Includes Electrical Junction Box and Impeller Bowl
MOTOR BUCKET	Precision CNC Machined Includes Bucket & Top Plate Modular for Moisture Protection and Ease of Repair
DIFFUSER	Aluminum Investment Casting CNC Precision Machined Flared 6 inch end for discharge hose attachment
IMPELLER	304 Stainless Steel Investment Casting CNC Precision Machined Dynamically Balanced
FASTENERS	304 Stainless Steel Socket and Button Head Screws
STRAINER SCREEN	Reinforced basket 1/2" 304 Stainless Steel Rods Corrosion Resistant and Durable for Rugged Use
MOTOR LEAD	10/4 AWG SEOOW Wire
LIFT	Axial-Flow
FLOW	1000 Gallons per Minute at 12 Feet of Lift
DUTY CYCLE	2 Minutes "ON" with 5 Minutes "OFF"
TEMPERATURE RANGE	Maximum Temperature +70° C Minimum Temperature -30° C
PUMP WEIGHT	60 lbs (includes motor and 30 ft. motor lead)

**Carry Pumps, Inc. | 1360 Prospect Ave | Caro, MI 48723
(800) 492-2779 | www.carrypumps.com | sales@carrypumps.com**