

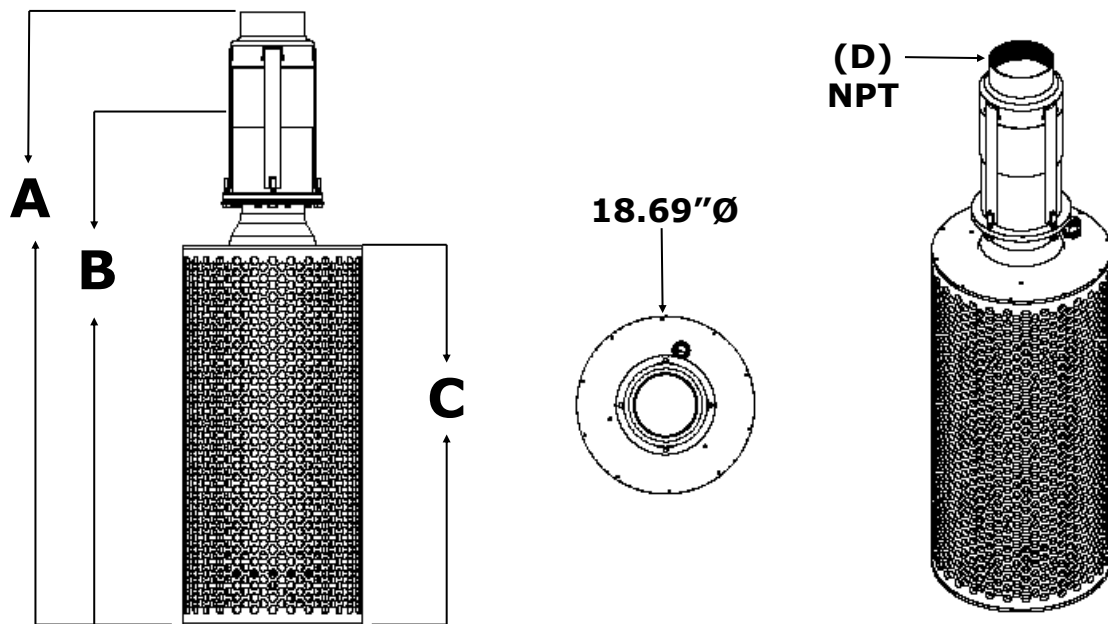

## CP06 SERIES - 3 PHASE TURBINE PUMP DIMENSIONS



HORSEPOWER	WEIGHT	(A) PUMP HEIGHT	(B) MINIMUM SUBMERGENCE	(C) SCREEN HEIGHT	(D) NPT
5 HP	190	39"	35"	24-1/2"	5"
7.5 HP	225	47-1/2"	37-1/2"	26-1/2"	5"
10 HP	245	49"	39"	27-1/2"	6"
15 HP	270	52"	42"	30"	6"
20 HP	195	55"	45"	33"	6"
25 HP	320	58"	48"	36"	6"
30 HP	350	63"	51"	39-1/2"	6"